

HEADS

U-TRONIC

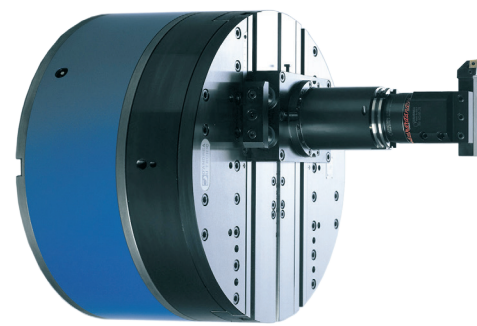

Medium and large NC heads for boring machines and special units

UT-SPECIALS

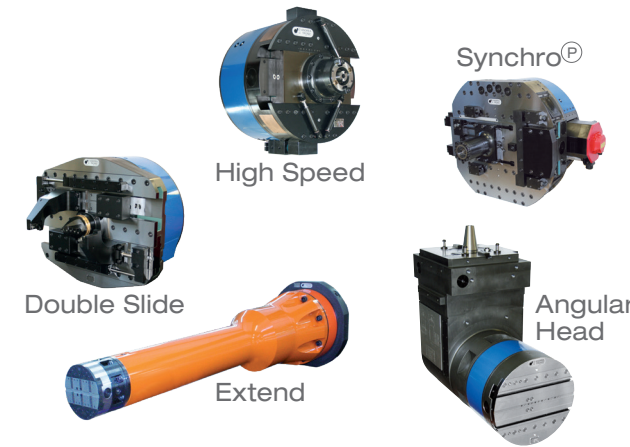

TA-CENTER



NC Heads for machining centers

TA-TRONIC



NC Heads for milling machines

U-COMAX



Axial drive NC heads for transfer machines and special units

AUTORADIAL



Automatic Heads for machining centers and milling machines

TOOLHOLDERS MONOBLOC

MONOd' High Quality Toolholders



MONOforce High Clamping Power Chucks



D'ANDREA in Lainate (Milan)



D'ANDREA in Castel Del Giudice (Isernia)



D'ANDREA S.p.A.
Via Garbagnate, 71 - 20045 Lainate (MI) Italy
t. +39 02.937532.1 - f. +39 02.93753240
info@dandrea.com - www.dandrea.com



181002005005 ed. 06/21

ONE STEP AHEAD

Made in Italy



TOOLHOLDERS

modulharddandrea MHD' testarossadandrea



Modular Toolholders MHD'

PSC Linea



Modular Toolholders PSC

MONOforce



High Clamping Power Chucks

MONOd'



Monobloc Toolholders



TOOLHOLDERS MODULAR

HEADS BORING - FACING - RADIUSING - THREADING

